

*AUTOMATIC 3 HANDS MULTIFUNCTION  
(RETROGRADE DAY, RETROGRADE DATE AND OPEN HEART)*

**A) DISPLAY**

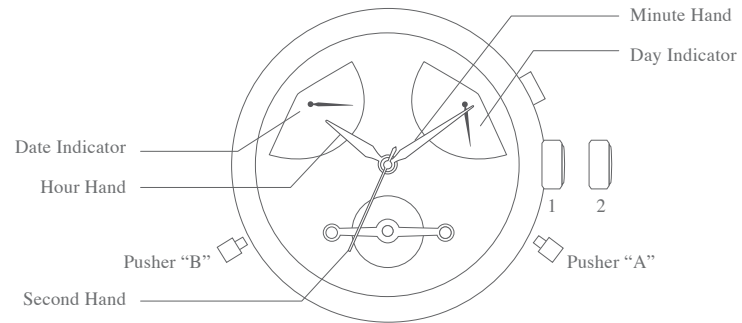

**B) WINDING THE MAINSPRING**

Automatic winding watch can be hand wound by turning the crown in its normal crown position. Wind 15-20 times and it will start to move naturally after shaking slightly.

**C) TIME SETTING**

1. Pull the crown to **position 2**.
2. Turn the crown to set Hour and Minute Hands.
3. Push the crown back to **position 1**.

**D) QUICK CHANGE CORRECT OR FOR DAY (Push "A" at 4 o'clock position)**

1. Pull the crown to **position 2**.
2. Pressing **pusher "A"** moves the day display forward by one day.
3. You must not use this quick change corrector between 11:30 p.m. and 5:30 a.m. because the automatic change mechanism is in operation between these times.

*AUTOMATIC 3 HANDS MULTIFUNCTION  
(RETROGRADE DAY, RETROGRADE DATE AND OPEN HEART)*

**A) DISPLAY**

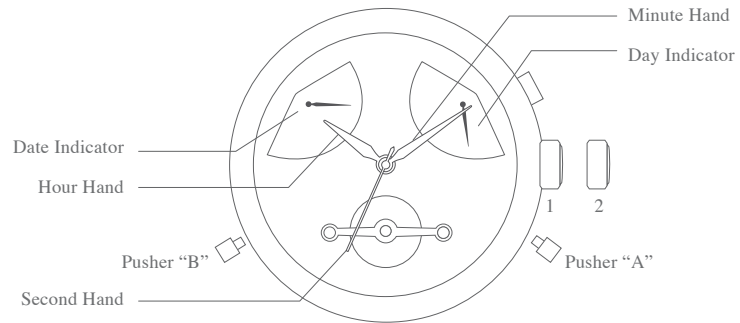

**E) QUICK CHANGE CORRECT OR FOR DATE (Push "B" at 8 o'clock position)**

1. Pull the crown to **position 2**.
2. Pressing **pusher "B"** moves the date forward by one day. You must not use this quick change corrector between 11:30 p.m. and 5:30 a.m. because the automatic change mechanism is in operation between these times.

**F) SET DATE & DAY**

1. Pull the crown to **position 2**.
2. Continue rotating hands until 6:00 a.m. Use the quick-change correctors to set the **day (pusher "A")** and **date (pusher "B")** then use the crown to turn the hands forwards until the current date is reached. You have now set the correct date and day.

**NOTE:**

**This watch MUST be worn for at least 8 (Eight) hours each day to ensure it is fully wound.  
An automatic watch will only wind when the watch is on your wrist and your arm moves.  
Winding the watch by the crown will put power on the spring but not enough to allow the watch to function fully.  
If your watch stops overnight or loses time it means it is not being fully wound.**